

My Road Running Board | Estribo My Road

KE 686 / Ram Classic 1500 CC/QC / 2500 CC 2019-
KE 687

COMPONENTS | Componentes

A	Hexagonal Bolt M10 x 1,50 x 30 Tornillo Hex. M10 x 1,50 x 30	25 (N.m) 18 (lb.ft.)	12	J	Lock Trava	6
B	Hexagonal Bolt M8 x 1,25 x 30 Tornillo Hex. M8 x 1,25 x 30	15 (N.m) 11 (lb.ft.)	6	K	Left Side Front Bracket Soporte Izquierdo Frontal	1
C	Hexagonal Bolt M6 x 1,00 x 30 Tornillo Hex. M6 x 1,00 x 30	9 (N.m) 6,63 (lb.ft.)	4	L	Right Side Front Bracket Soporte Derecho Frontal	1
D	Hexagonal Nut M10 x 1,50 Tuerca Hex. M10 x 1,50	25 (N.m) 18 (lb.ft.)	4	M	Left Side Center Bracket Soporte Izquierdo Central	1
E	Hexagonal Nut M8 x 1,25 Tuerca Hex. M8 x 1,25	25 (N.m) 18 (lb.ft.)	6	N	Right Side Center Bracket Soporte Derecho Central	1
F	Flat Washer M10 x 2,00 x 21 Arandela Plana M10 x 2,00 x 21		16	O	Left Side Rear Bracket Soporte Izquierdo Trasero	1
G	Flat Washer M8 x 2,00 x 24 Arandela Plana M8 x 2,00 x 24		12	P	Right Side Rear Bracket Soporte Derecho Trasero	1
H	Flat Washer M6 x 1,6 x 18 Arandela Plana M6 x 1,6 x 18		4	Q	Left Running Board Estribo Izquierdo	1
I	Plastic Washer Arandela de Plastico		6	R	Right Running Board Estribo Derecho	1

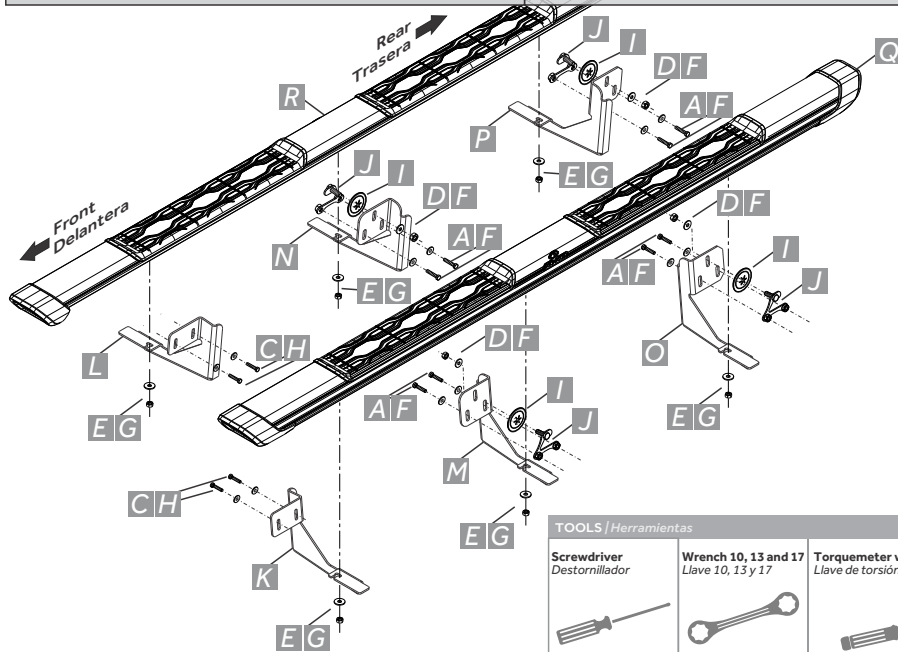

TOOLS | Herramientas

Screwdriver
Destornillador



Wrench 10, 13 and 17
Llave 10, 13 y 17



Torque meter with 10, 13 y 17 socket
Llave de torsión con casquillo 10, 13 y 17



My Road Running Board | Estribo My Road

KE 686 / Ram Classic 1500 CC/QC / 2500 CC 2019-
KE 687

COMPONENTS | Componentes

A	Hexagonal Bolt M10 x 1,50 x 30 Tornillo Hex. M10 x 1,50 x 30	25 (N.m) 18 (lb.ft)	12	J	Lock Trava	6
B	Hexagonal Bolt M8 x 1,25 x 30 Tornillo Hex. M8 x 1,25 x 30	15 (N.m) 11 (lb.ft)	6	K	Left Side Front Bracket Soporte Izquierdo Frontal	1
C	Hexagonal Bolt M6 x 1,00 x 30 Tornillo Hex. M6 x 1,00 x 30	9 (N.m) 6,63 (lb.ft)	4	L	Right Side Front Bracket Soporte Derecho Frontal	1
D	Hexagonal Nut M10 x 1,50 Tuerca Hex. M10 x 1,50	25 (N.m) 18 (lb.ft)	4	M	Left Side Center Bracket Soporte Izquierdo Central	1
E	Hexagonal Nut M8 x 1,25 Tuerca Hex. M8 x 1,25	25 (N.m) 18 (lb.ft)	6	N	Right Side Center Bracket Soporte Derecho Central	1
F	Flat Washer M10 x 2,00 x 21 Arandela Plana M10 x 2,00 x 21		16	O	Left Side Rear Bracket Soporte Izquierdo Trasero	1
G	Flat Washer M8 x 2,00 x 24 Arandela Plana M8 x 2,00 x 24		12	P	Right Side Rear Bracket Soporte Derecho Trasero	1
H	Flat Washer M6 x 1,6 x 18 Arandela Plana M6 x 1,6 x 18		4	Q	Left Running Board Estribo Izquierdo	1
I	Plastic Washer Arandela de Plastico		6	R	Right Running Board Estribo Derecho	1

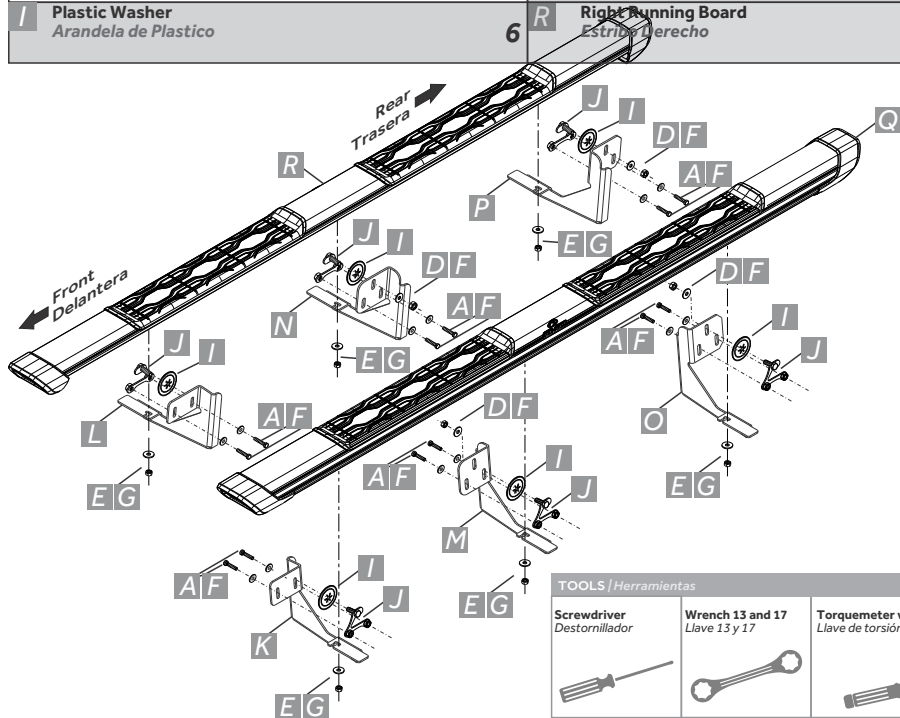

TOOLS | Herramientas

Screwdriver
Destornillador



Wrench 13 and 17
Llave 13 y 17



Torquemeter with 13 and 17 socket
Llave de torsión con casquillo 13 y 17





INSTALLATION INSTRUCTIONS

MANUAL DE INSTALACIÓN

My Road Running Board | Estribo My Road

KE 686 / Ram Classic 1500 CC/QC / 2500 CC 2019-
KE 687

COMPONENTS | Componentes

A	Hexagonal Bolt M10 x 1,50 x 30 Tornillo Hex. M10 x 1,50 x 30	25 (N.m) 18 (lb.ft)	12	J	Lock Trava	6
B	Hexagonal Bolt M8 x 1,25 x 30 Tornillo Hex. M8 x 1,25 x 30	15 (N.m) 11 (lb.ft)	6	K	Left Side Front Bracket Soporte Izquierdo Frontal	1
C	Hexagonal Bolt M6 x 1,00 x 30 Tornillo Hex. M6 x 1,00 x 30	9 (N.m) 6,63 (lb.ft)	4	L	Right Side Front Bracket Soporte Derecho Frontal	1
D	Hexagonal Nut M10 x 1,50 Tuerca Hex. M10 x 1,50	25 (N.m) 18 (lb.ft)	4	M	Left Side Center Bracket Soporte Izquierdo Central	1
E	Hexagonal Nut M8 x 1,25 Tuerca Hex. M8 x 1,25	25 (N.m) 18 (lb.ft)	6	N	Right Side Center Bracket Soporte Derecho Central	1
F	Flat Washer M10 x 2,00 x 21 Arandela Plana M10 x 2,00 x 21		16	O	Left Side Rear Bracket Soporte Izquierdo Trasero	1
G	Flat Washer M8 x 2,00 x 24 Arandela Plana M8 x 2,00 x 24		12	P	Right Side Rear Bracket Soporte Derecho Trasero	1
H	Flat Washer M6 x 1,6 x 18 Arandela Plana M6 x 1,6 x 18		4	Q	Left Running Board Estribo Izquierdo	1
I	Plastic Washer Arandela de Plastico		6	R	Right Running Board Estribo Derecho	1

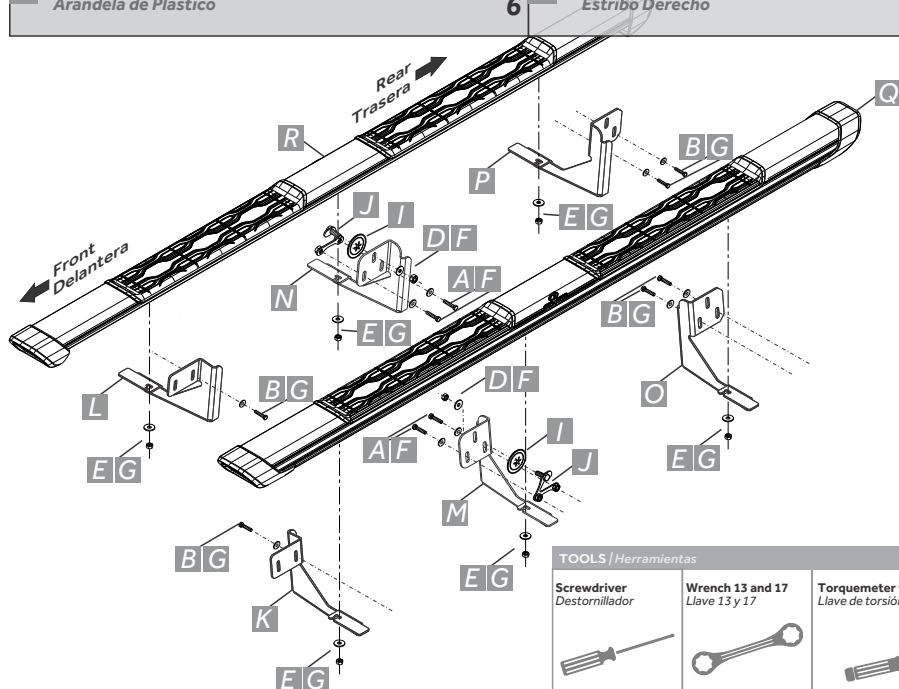

TOOLS | Herramientas

Screwdriver
Destornillador



Wrench 13 and 17
Llave 13 y 17



Torquemeter with 13 and 17 socket
Llave de torsión con casquillo 13 y 17



Left side bracket and running board fixing detail. Same procedure for the right side.

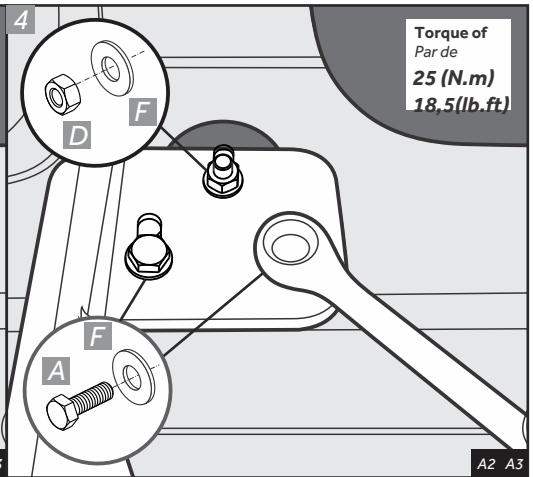
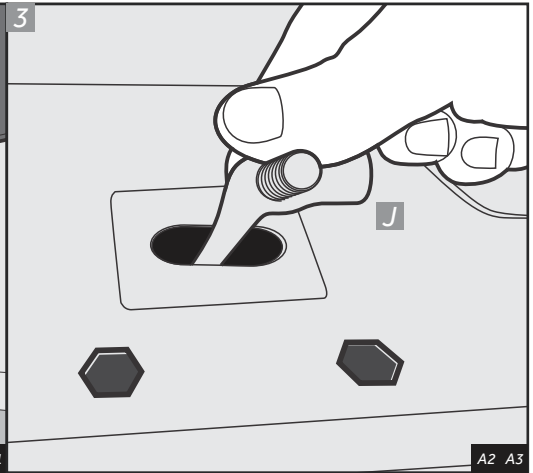
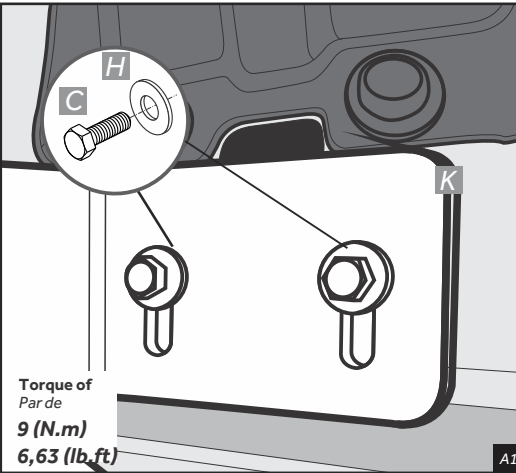
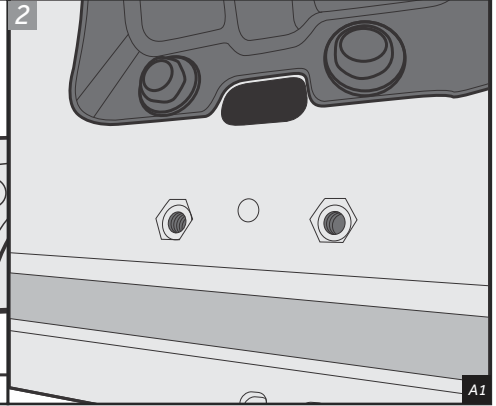
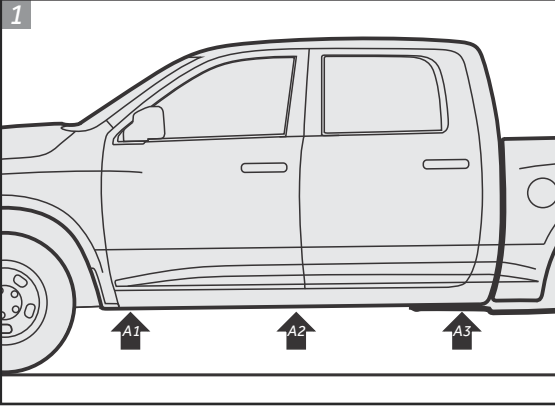

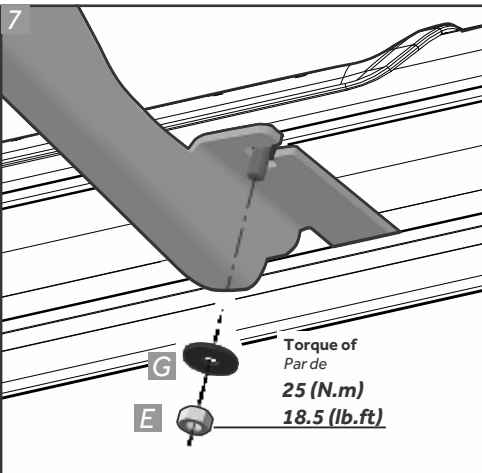
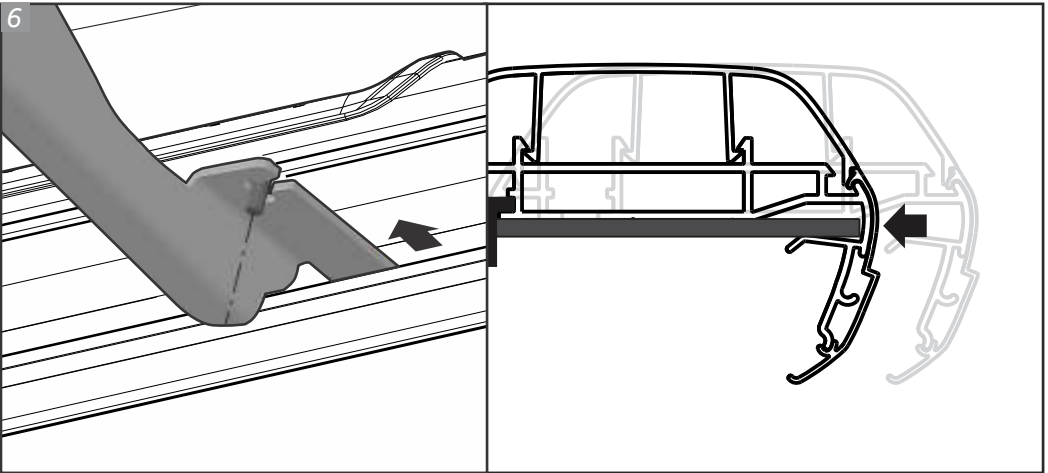
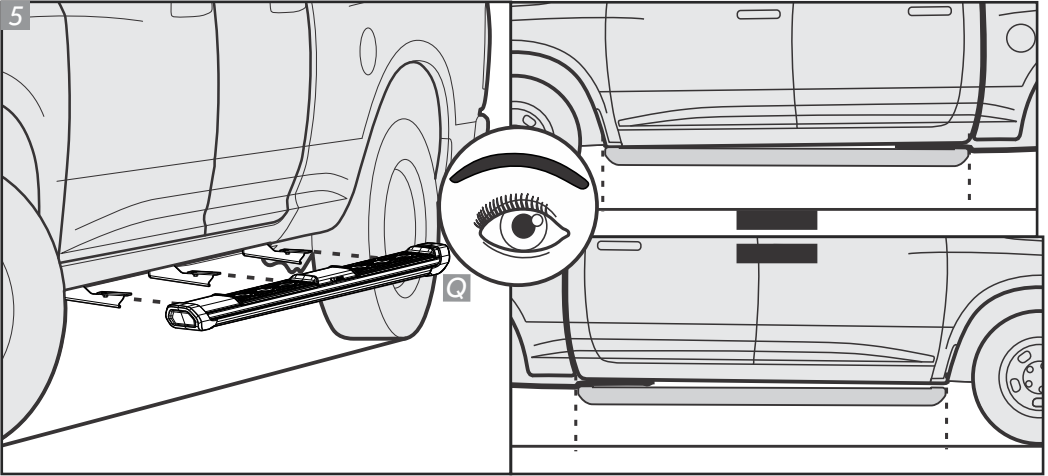

WARRANTY / GARANTÍA

Keko Accesorios S.A. warrants to the original purchaser of Keko's products, for the period of three years, from the date of the purchase, that the product is free from defects in raw material, workmanship or finishing and it is Keko's obligation, under this warranty, to repair or replace, at Keko's election, any part or parts of the product which prove to be defective. This warranty shall not apply to any product which has suffered damage from collision, mishandling, misuse, incorrect cleaning, and incorrect installation or to any product that has been altered from its original conception or had its serial number (available in the product and packaging) removed.

Maintenance, cleaning and durability: for cleaning use only water, neutral soap and sponge or flannel. Periodically use automotive wax to conserve the chrome-plated parts. Never use chemicals or abrasive products not to scratch and expose the product to corrosion.

Warranty Claim: request the shop where the accessory was purchased to evaluate the defect. If proved to be Keko's liability, the part will be repaired or replaced without charge. The repair or replacement of the parts will not result in extension of the warranty term provided.

Keko's Liability Term: Keko does not assume any responsibility for the mishandling or wrong installation of its products. After using the product/packaging we recommend the appropriate destination for each type of material according applicable law.

Keko's products are merely decorative and do not guarantee the safety of the occupant or vehicle in case of a rollover or other vehicle accident.

Keko Accesorios S.A. le concede al comprador original de los productos Keko garantía de tres años a partir de la fecha de compra original por defecto de fabricación en la materia prima, mano de obra o terminación, en servicio o durante el uso normal, siempre que debidamente comprobados. Se excluyen de la garantía los daños ocasionados por colisión, uso indebido del producto como exceso de carga, limpieza incorrecta, instalación inadecuada, alteración de la concepción original del producto o cuando se haya retirado el número de serie (disponible en el producto y en el empaque) de fabricación.

Conservación, limpieza y durabilidad: para limpieza, utilizar solamente agua, jabón neutro, esponja o franela. Para la conservación de productos con terminación cromo, utilizar periódicamente cera para automóviles. Nunca utilizar productos químicos o abrasivos, dado que sus componentes arañan la terminación y exponen los productos con terminación de cromo a la corrosión, perjudicando los productos de plástico.

Solicitud de la garantía: solicitar la evaluación del problema en el establecimiento donde se efectuó la compra. En caso de reclamación procedente, se cambiará la pieza sin cargo para el propietario. La reparación o cambio de las partes del equipo no representa prolongación de su plazo de garantía original.

Término de responsabilidad de los productos Keko: Keko no asume ninguna responsabilidad en virtud de cualquier tipo de avería que resulte de mala utilización/instalación de sus productos. Después de la utilización del producto/empaque recomendamos el destino apropiado para cada tipo de material, según la legislación aplicable.

Los productos Keko se comercializan como accesorios meramente decorativos y no se deben considerar como medida de protección del vehículo o de sus pasajeros en caso de colisión o volcamiento.

CUSTOMER SERVICE
1-855-476-3893
kekousa@kekousa.com